

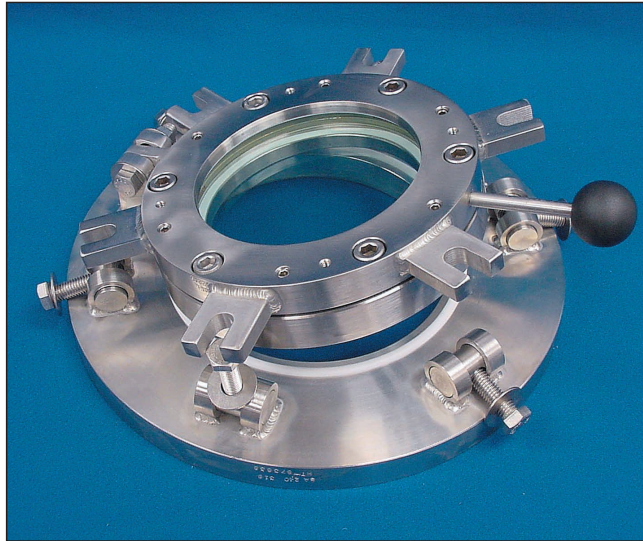

## Hinged Closure Sight Glass



### Description:

The Hinged Closure Sight Glass provides immediate access to the process, and is designed for mounting PresPressure Products' Model B or Model L units (depending on pressure requirements) to be hinged and sealed on an O-ring or gasket. Different materials of construction are available to meet your process needs. Units are designed for a weld pad or flange connection (ANSI, DIN, or special bolt pattern).

### Materials of Construction:

- 1. Sight Glass:** Refer to Model L Weld or Model B Weld Units (depending upon pressure)
- 2. Weld Pad or Flange:** 316 or 304 Stainless Steel SA-240; Carbon Steel PVQ; Hastelloy; Monel; Alloy 20; Titanium; Aluminum; etc.
- 3. O-Ring Seal or Gasket:** Teflon®; Viton®; Silicone; EPDM; Graphite; Buna-N; etc.
- 4. Swing Bolts:** 316 or 304 Stainless Steel; Carbon Steel
- 5. Hinge:** 316 or 304 Stainless Steel; Carbon Steel

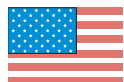
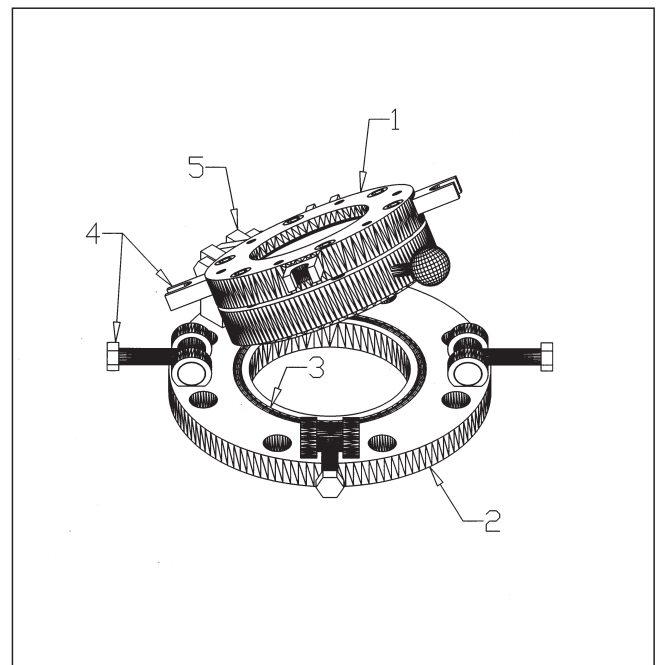

MADE IN THE USA

