

## Model L Flange

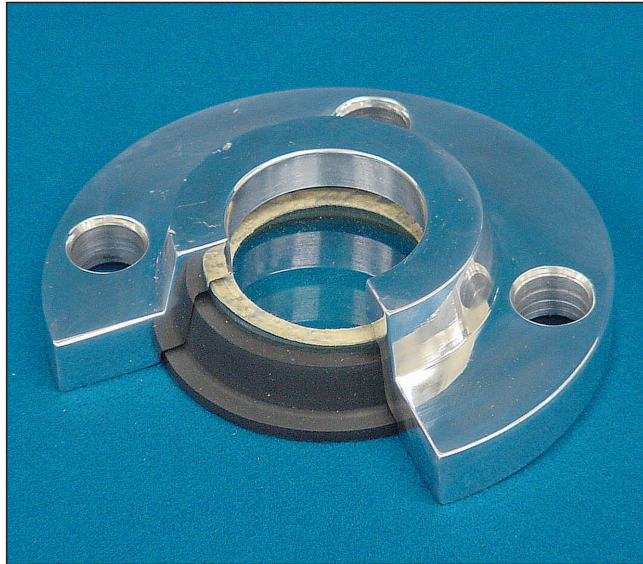

### Description:

The Model L Flange is developed to satisfy the need for pressure requirements from full vacuum to 100 psi while still providing the safety of PresSure Products' higher-pressure and temperature units. The Model L Flange unit mounts on standard 150 psi ANSI B16.5 (2" to 8") flange accommodations, and is rated for temperatures up to 450°F. The wetted parts are the seal, the bottom cushion gasket, and the glass lens, held in place by either a carbon steel or stainless steel flange. The unit can be provided with a Silicone, Viton®, Teflon®, or EPDM seal, and different materials of construction are available to meet your process needs. Applications requiring DIN standards or non-ANSI flanges are available upon request; no metal parts are in contact with the process and no mating gaskets required.

### Materials of Construction:

- 1. Flange:** 316 or 304 Stainless Steel SA-182; Carbon Steel SA-105
- 2. Lens:** Two-Piece Laminated Tempered Soda Lime (Standard); Tempered or Annealed Borosilicate; Quartz; Lexan; Acrylic
- 3. Lens Cushion Gaskets:** Teflon®; Grafoil®; Gylon®; Blue-Gard®; etc.
- 4. Seal:** Teflon®; Viton®, Silicone; EPDM; etc.

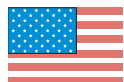
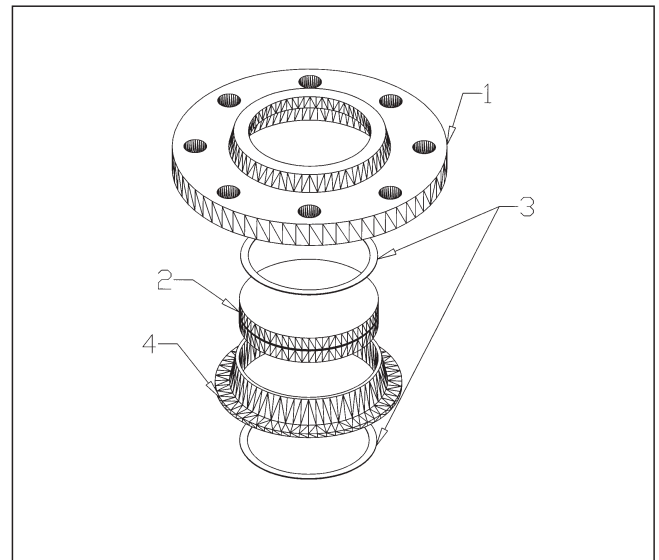

MADE IN THE USA

