

Type I & II – with Threaded Retainer Cap



Description:

Type I and II Sanitary Sight Glasses are designed for sanitary applications used in the food, dairy, and pharmaceutical industries. Type I and II Glasses have a threaded retainer cap that can be removed, which allows easy access to the inside of the lens for cleaning and/or sampling of the product.

Materials of Construction:

- 1. Body:** 304L or 316L Stainless Steel
- 2. Caps:** 304L or 316L Stainless Steel
- 3. Glass:** Tempered Soda Lime; Tempered Borosilicate (Pyrex); Quartz; Polycarbonate (Lexan); Acrylic
- 4. Gaskets:** Teflon[®]; Viton[®]; Buna-N; Silicone; EPDM; Gore-Tex[®]; etc.

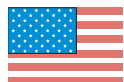
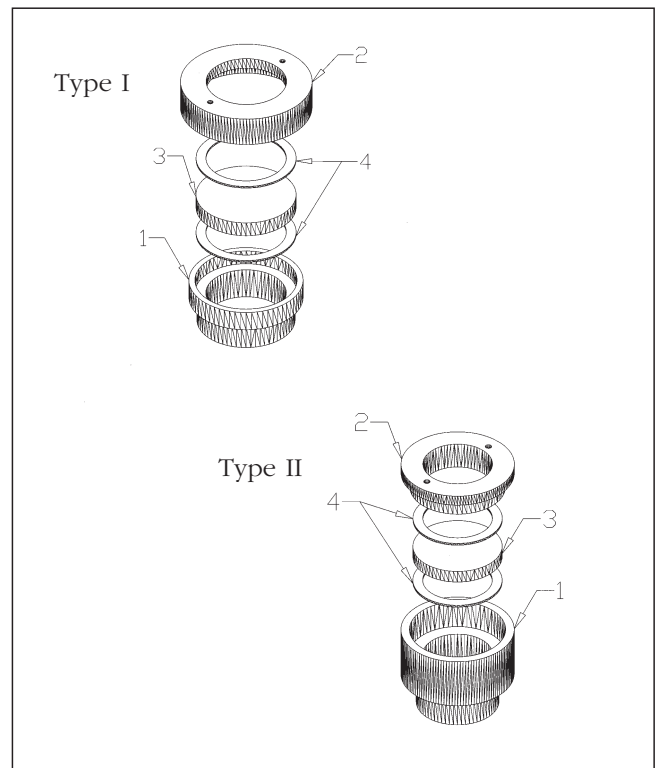

MADE IN THE USA

Type I & II – with Threaded Retainer Cap

Engineering Information:

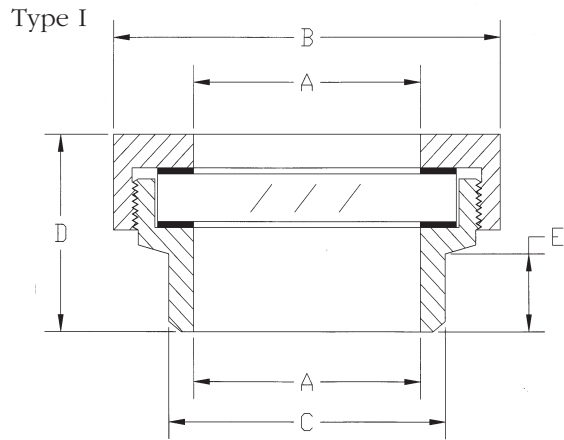

Size	A	B	C	D	E
65	2 ⁹ / ₁₆	4 ³ / ₈	3 ¹ / ₈	2 ¹ / ₁₆	¹³ / ₁₆
80	3 ¹ / ₈	4 ⁹ / ₁₆	3 ¹¹ / ₁₆	2 ¹ / ₄	⁷ / ₈
100	3 ¹⁵ / ₁₆	5 ⁹ / ₁₆	4 ¹ / ₂	2 ¹¹ / ₁₆	1 ¹ / ₄
125	4 ¹⁵ / ₁₆	6 ⁹ / ₁₆	5 ³ / ₈	2 ¹ / ₄	³ / ₄

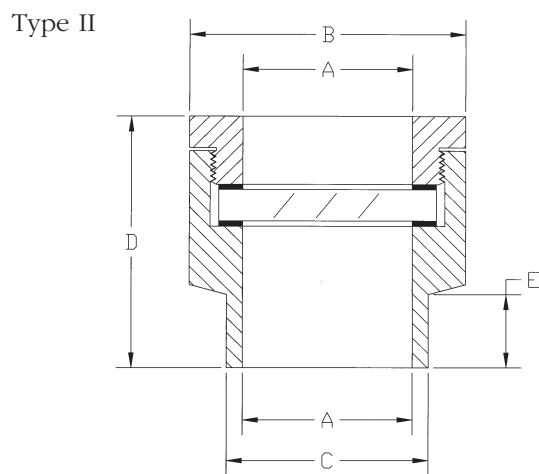

Size	A	B	C	D	E
65	2	3 ¹ / ₄	2 ³ / ₈	3	⁷ / ₈
80	3	4 ¹ / ₄	3 ¹ / ₂	3 ¹ / ₄	⁷ / ₈
100	4	5 ¹ / ₄	4 ¹ / ₂	3 ¹ / ₂	1
125	5	6 ¹ / ₄	5 ⁵ / ₈	3 ³ / ₄	1 ¹ / ₁₆