

Spray Ring Assembly

Engineering Information:

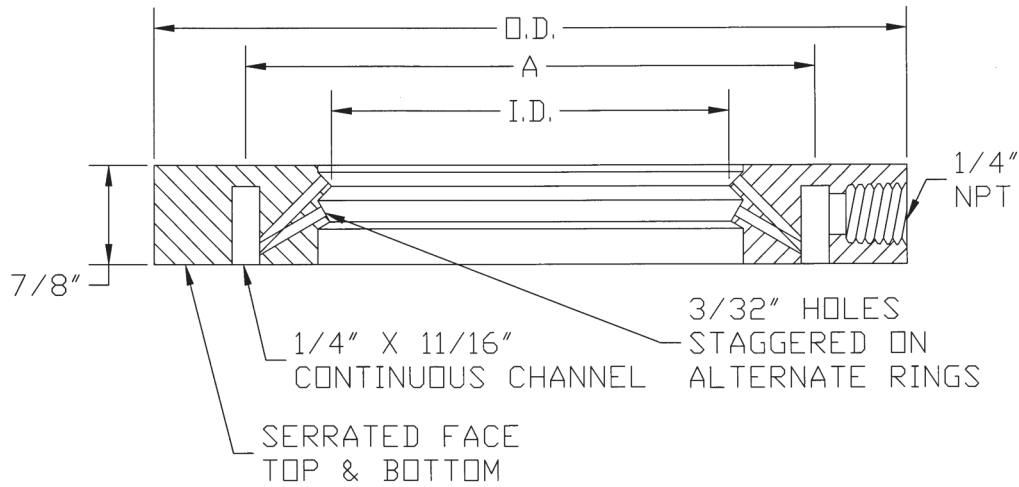

All dimensions in inches.

Sight Glass Size	O.D.	I.D.	A	Number of Spray Holes
2-150	4	1 $11/16$	2.845	8
2-300	4 $1/4$	1 $11/16$	2.845	8
3-150	5 $1/4$	2 $5/8$	4.034	8
3-300	5 $3/4$	2 $5/8$	4.034	8
4-150	6 $3/4$	3 $9/16$	5.107	16
4-300	7	3 $9/16$	5.107	16
6-150	8 $5/8$	5 $1/2$	7.000	16
6-300	8 $1/2$	5 $1/2$	7.000	16
8-150	10 $7/8$	7 $7/16$	9.000	16
8-300	12	7 $7/16$	9.000	16

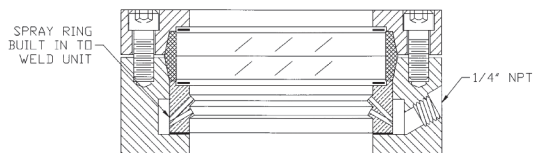

- The outside diameter of this spray ring is machined to fit inside of the flange bolts of the mating 150 or 300 psi flange, thereby centering the Spray Ring on the gasket of the mating flange.
- Higher-pressure spray rings will be machined with outside diameter matching raised face of flange.
- Closed Channel Spray Ring (not shown) available upon request for applications where open channel sealing cannot be accomplished.